

寸法	d	φD	L
10×50	R 3/8	17	50
10×75	R 3/8	17	75
10×100	R 3/8	17	100
10×125	R 3/8	17	125
10×150	R 3/8	17	150
13×50	R 1/2	22.5	50
13×65	R 1/2	22.5	65
13×75	R 1/2	22.5	75
13×100	R 1/2	22.5	100
13×125	R 1/2	22.5	125
13×150	R 1/2	22.5	150
13×200	R 1/2	22.5	200
20×50	R 3/4	27	50
20×65	R 3/4	27	65
20×75	R 3/4	27	75
20×100	R 3/4	27	100
20×125	R 3/4	27	125
20×150	R 3/4	27	150
20×200	R 3/4	27	200
25×50	R 1	34	50
25×65	R 1	34	65
25×75	R 1	34	75
25×100	R 1	34	100
25×125	R 1	34	125
25×150	R 1	34	150
25×200	R 1	34	200
30×75	R1 1/4	45	75
30×100	R1 1/4	45	100
30×125	R1 1/4	45	125
30×150	R1 1/4	45	150
30×200	R1 1/4	43	200

寸法	d	φD	L
40×75	R1 1/2	51.2	75
40×100	R1 1/2	51.2	100
40×125	R1 1/2	51.2	125
40×150	R1 1/2	51.2	150
40×200	R1 1/2	48	200
50×75	R 2	61.5	75
50×100	R 2	61.5	100
50×125	R 2	61.5	125
50×150	R 2	61.5	150
50×200	R 2	60	200
65×100	R2 1/2	76	100
65×125	R2 1/2	76	125
65×150	R2 1/2	76	150
65×200	R2 1/2	76	200
75×100	R 3	88	100

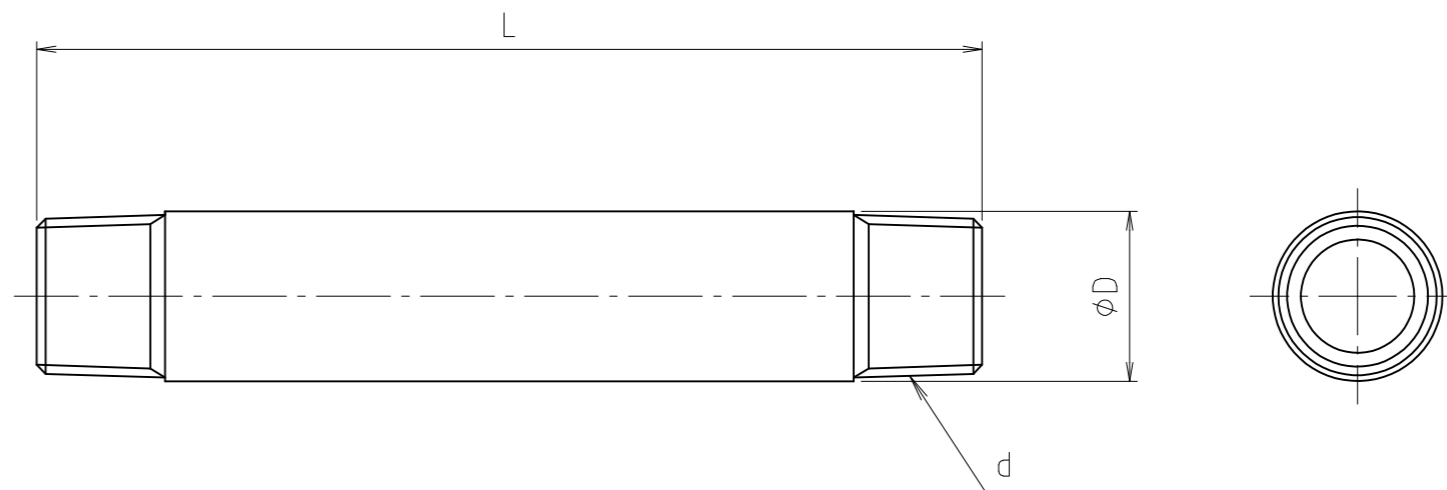

寸法30・40・50×200、65、75は加工肌

1	本体	青銅棒	CAC406C	
番号	部品名	材質名	材質記号	備考
品名	砲金長ニップル			尺度 —
品番	M155MMN			原図 A3
大阪市北区天満1丁目6-7				フォルダ 1
ミヤコ株式会社				図番 M155MMN-06